

APPROVED BY _____

DATE _____

PAINT CODE _____

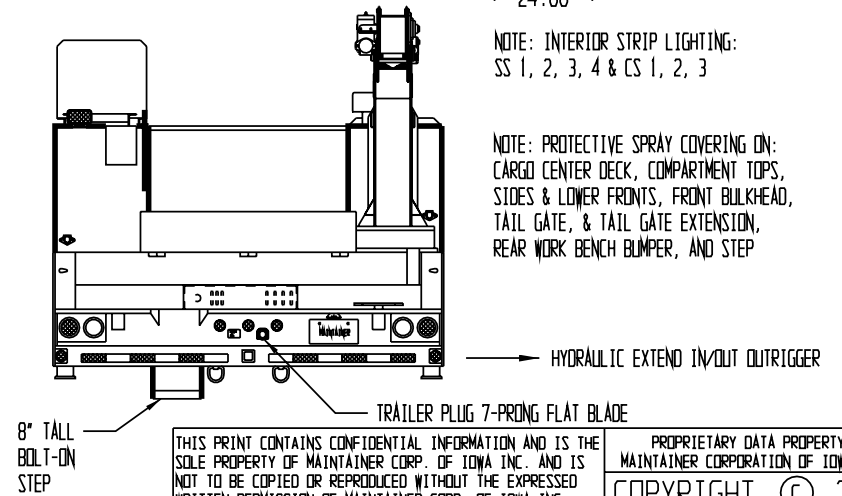
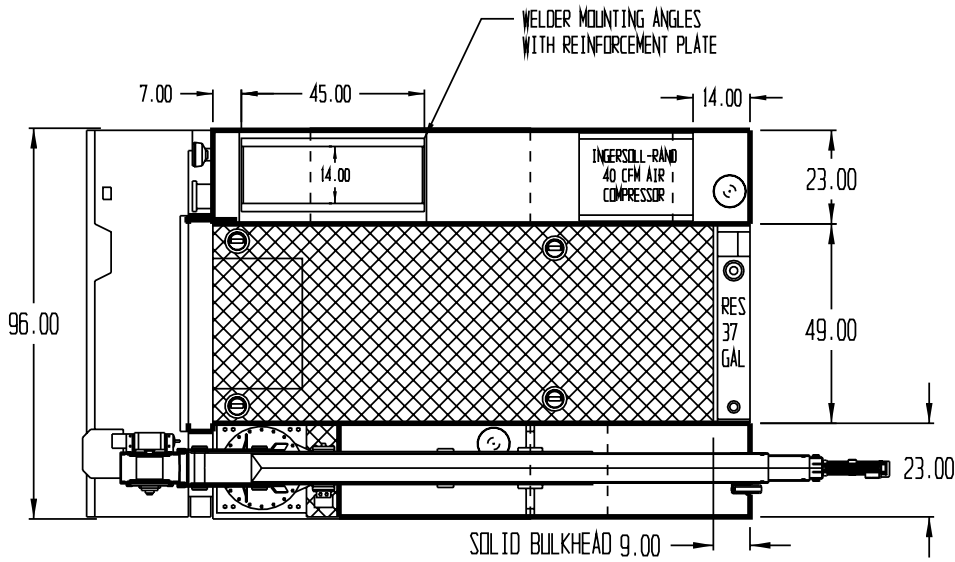
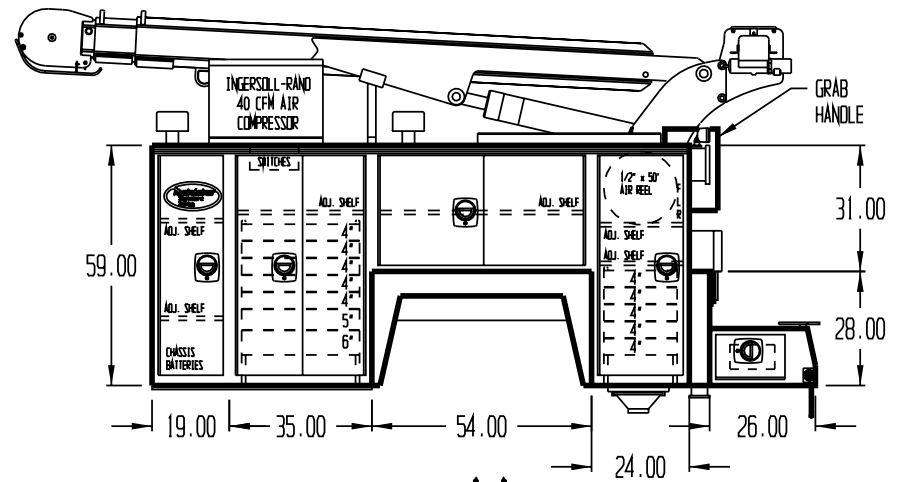
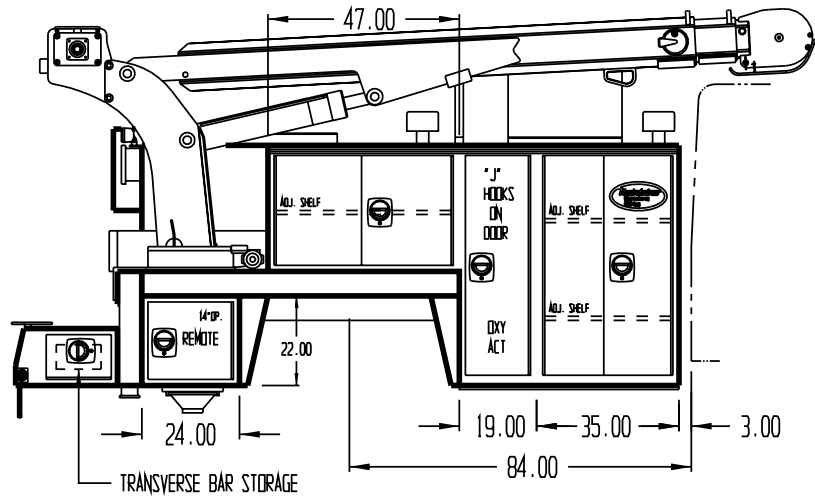

NOTE: INTERIOR STRIP LIGHTING: SS 1, 2, 3, 4 & CS 1, 2, 3

NOTE: PROTECTIVE SPRAY COVERING ON: CARGO CENTER DECK, COMPARTMENT TOPS, SIDES & LOWER FRONTS, FRONT BULKHEAD, TAIL GATE, & TAIL GATE EXTENSION, REAR WORK BENCH BUMPER, AND STEP

NOTE: 20 GALLON AIR STORAGE IN CHASSIS FRAME

NOTE: USABLE CENTER DECK CARGO WIDTH 48.50"

NOTE: 8" SILLS & 4" X-MEMBERS

PLEASE REPORT ANY ERRORS FOUND ON THIS PRINT

THIS PRINT CONTAINS CONFIDENTIAL INFORMATION AND IS THE SOLE PROPERTY OF MAINTAINER CORP. OF IOWA INC. AND IS NOT TO BE COPIED OR REPRODUCED WITHOUT THE EXPRESSED WRITTEN PERMISSION OF MAINTAINER CORP. OF IOWA INC.

PROPRIETARY DATA PROPERTY OF MAINTAINER CORPORATION OF IOWA, INC.

COPYRIGHT © 2000

Thaintainer

Corporation of Iowa, Inc.
P.O. Box 349 1701 S. 2nd Avenue
Sheldon, Iowa 51201

LOS DIMENSIONS ARE IN INCHES
GENERAL TOLERANCES

| | |
|---------------------------|------------------------------------|
| BREAK ALL EDGES .01 X 45° | ANGULAR ± 1° .XX ± .03 .XXX ± .005 |
| LOS RADIUS | LOS ANGLES |

MATERIAL:

| | |
|-------------|---------|
| SCALE: 1:32 | SIZE: B |
|-------------|---------|

MADE IN THE USA

DRAWING NUMBER: SIG-2

DFTM. STZ DATE: 4/2/09

10000TT-2-084 SIG-2