

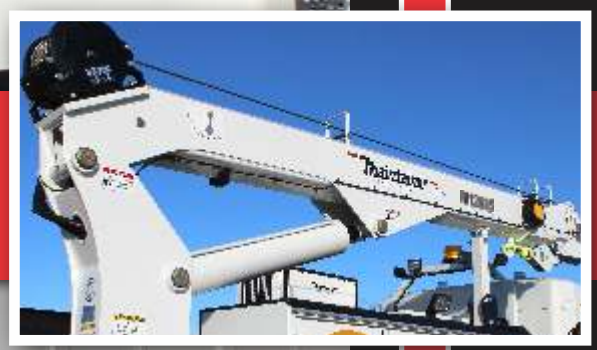

Maintainer

H12025 CRANE



SPECIFICATIONS

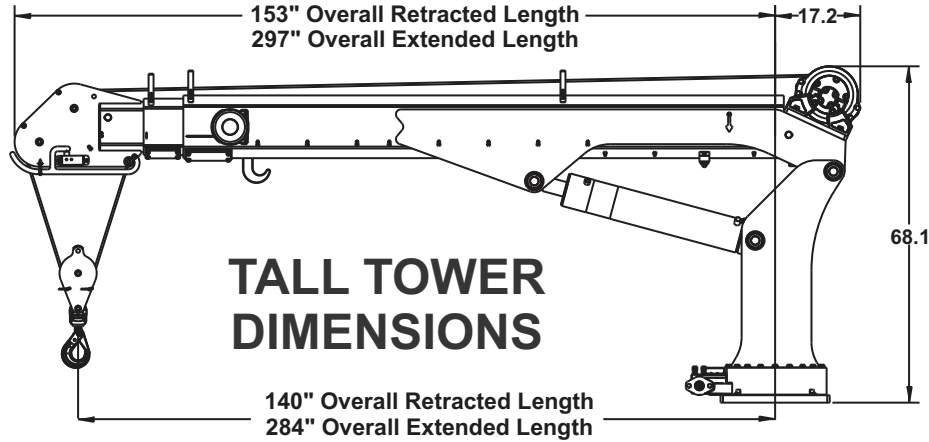

specifications

- 2466 lbs. (998 KGS)
- 22" x 24" Mounting Space Required
- Mounting requires (8) 7/8-9 (GRD-8) bolts
- Hydraulic Requirements: 10-12 GPM@3000 PSI



ratings

features

- 12,000 lb. max. capacity
- 90,000 ft*lb capacity
- 25' hydraulic reach
- Advanced Crane Control - standard
- Boom-Mounted planetary winch
- Dual part line standard - single part capable
- Total operational range 91° (-13 to +78)
- Low profile double sheave design
- Anti-Two block relocation (*left side*)
- User-Friendly load block storage
- 120' of 7/16" diameter wire rope
- 615° of rotation
- Hexagonal boom
- Tall tower configurations
- Wireless remote - standard
- Closed-center/load sensing hydraulic system (*open center optional*)
- OSHA 1910.180/ANSI B30.5 compliant



H12025 CRANE CAPACITY CHART 90,000 FT*LB CRANE RATING

HYDRAULIC EXTENSION TO 24' 9"

MAX SINGLE LINE CAPACITY IS 6000 LBS (2722 KG)
FOR GREATER LOADS USE 2 PART LINE
OUTRIGGERS MUST BE EXTENDED AND DOWN

CAPACITIES ARE IN LBS. (*KGS.)
DEDUCT FROM CAPACITIES THE WEIGHTS OF LOAD HANDLING DEVICES

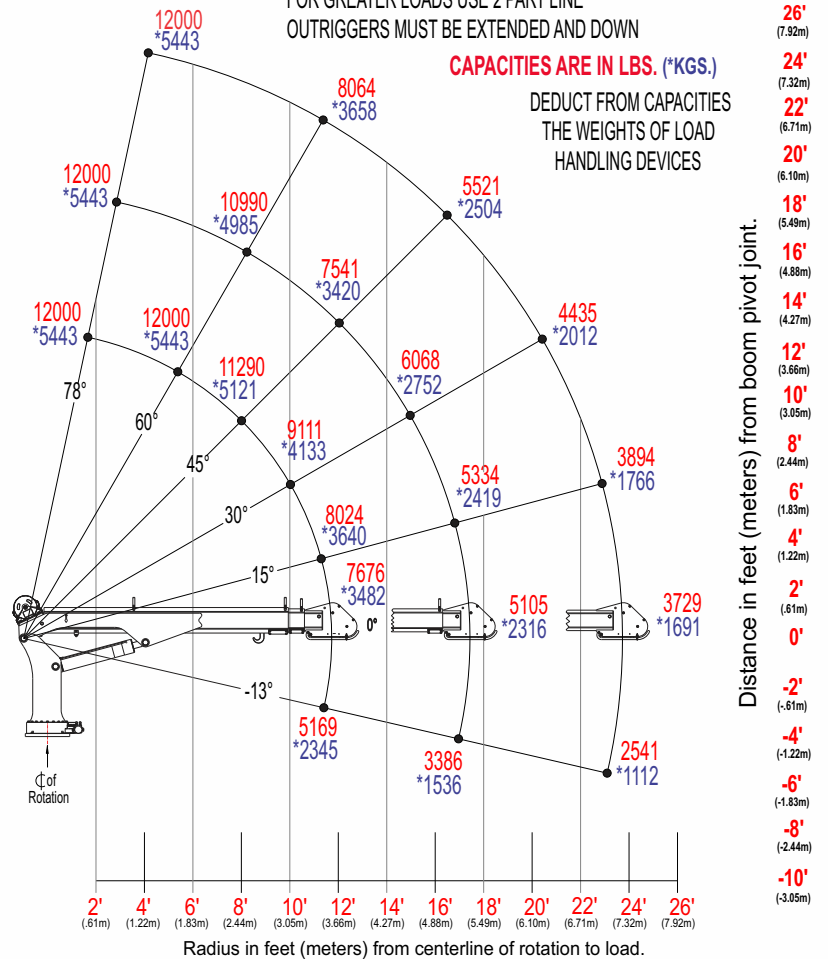

WWW.

Maintainer.com

MAINTAINER CORPORATION OF IOWA, INC.
1701 2nd Avenue | Sheldon, Iowa 51201 | Ph: 800-831-8588