

SIGNATURE SERIES 2

14' STEEL WELDER BODY

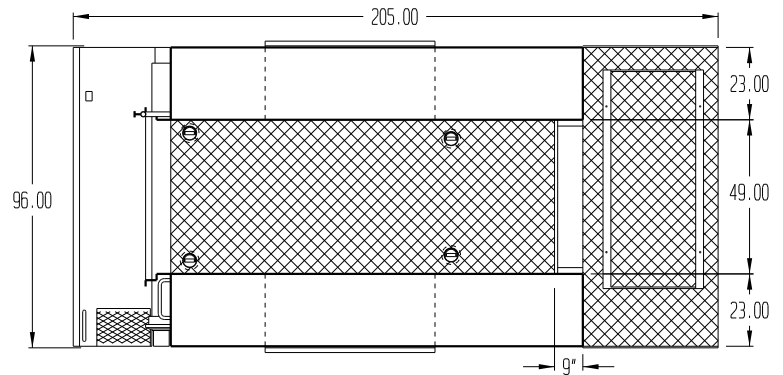

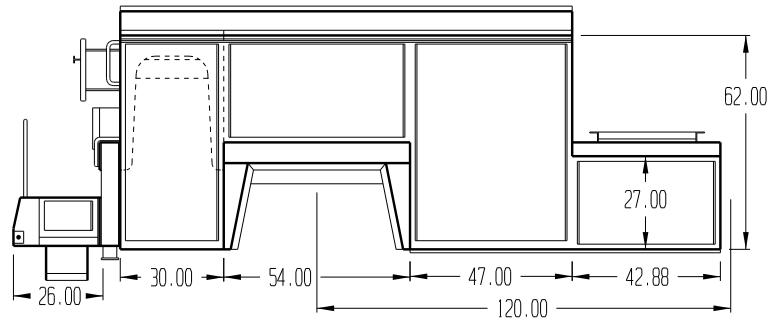
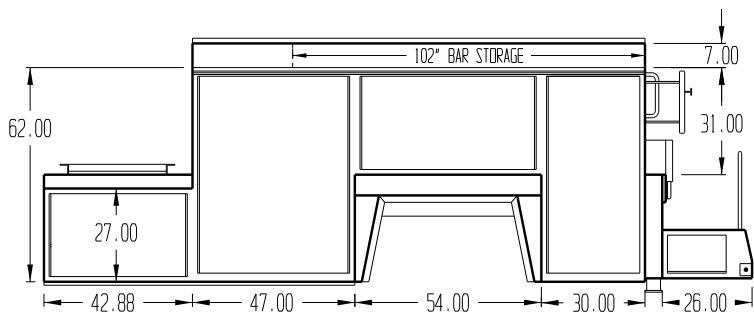

STANDARD FEATURES

- Body, crane tower, outriggers rated at 100,000 ft*lb. moment rating
- Body Substructure: frame construction of 10" tall formed channel main sills and additional longitudinal channels with cross-cut formed members and tubing
- 12 gauge A60 galvanized steel compartment construction
- 49" wide center deck width
- 62" tall x 23" deep compartments
- 26" rear workbench bumper with lighted recessed step
- 102" L boring bar storage compartment
- Ribbed compartment floors
- (6) flush mounted D-ring tie downs
- 10" slam-latch aluminum tailgate
- 3/16" single piece recessed aluminum doors
- D-ring stainless steel compression door latches
- Gas spring door holders
- Aluminum drip rail above compartments
- 250 lb. capacity adjustable aluminum shelving
- 3-point center deck access with safety yellow handles
- PPG etch-primed, urethane-primed and painted
- Undercoating
- Master lock system
- 97 db backup alarm
- LED marker and tail lights
- I.C.C. safety kit (2.5 lb. ABC fire extinguisher & hazard reflectors)
- CAN Control System standard with 65620 cranes and larger
- Patented Pressurized Storage System (PSS)
- Rear strobe lights

COMPATIBLE MAINTAINER CRANES

- | | | | | |
|----------|---------|---------|---------|---------|
| • EH3516 | • H3516 | • 65620 | • 85624 | • 10630 |
| • EH4520 | • H4520 | • 75624 | • 85630 | • 12625 |
| • EH5520 | • H5520 | • 75630 | • 10625 | • 12630 |
| | | | • 10625 | • 14625 |

SIG SERIES 2 OPTIONS

- | | |
|----------------------------------|--------------------------------------|
| • DualLock drawers and Bolt Bins | • Safety strobe lighting |
| • Vises and vise mounting plates | • Slide top center deck covers |
| • Interior LED strip lighting | • Protective spray covering packages |
| • Exterior LED flood lights | • Hydraulic driven air compressors |
| • Gas/diesel driven welders | • All-in-one APU units |
| • Light bars | • Other body lengths available |
| • Wheel flares | |

MAINTAINER M-CONNECT | **OPTIONAL**

Only available on 65620 cranes and larger

With our M-Connect telematics platform, you can monitor your fleet in real time. M-Connect gives you information such as GPS location, crane utilization that includes alerts if potential unsafe usage is being performed. Other features include crane hours, PTO hours, boom stow, outrigger stow, live weight display on crane remote, boom angle, boom pressure, load radius, air compressor hours. M-Connect is capable of integrating with existing telematic platforms such as Samara, Geotab, Verizon Connect, and Fleet IO.



1701 2nd Ave | Sheldon, IA 51201 | 800-831-8588 | maintainer.com

